

SINAMICS G110D

Distributed inverters

0.75 kW to 7.5 kW (1.0 hp to 10 hp)

5



5/2 **SINAMICS G110D distributed inverters**

- 5/2 Overview
- 5/2 Applications
- 5/3 Selection and ordering data
- 5/3 Benefits
- 5/4 Design
- 5/5 Integration
- 5/6 Configuration
- 5/6 Technical specifications
- 5/10 Characteristic curves
- 5/11 Dimensional drawings

5/13 **Recommended line components**

- 5/13 Overview
- 5/13 Selection and ordering data

5/14 **DC link components**

- 5/14 Braking resistors

5/15 **Supplementary system components**

- 5/15 Intelligent Operator Panel IOP Handheld
- 5/16 Manual-local control with keyswitch
- 5/16 MMC memory card
- 5/17 Card holder for MMC/SD memory card
- 5/17 RS232 interface cable for communication with a PC
- 5/17 USB interface cable for communication with a PC
- 5/17 Adapter to mount SINAMICS G110D instead of SIRIUS M200D motor starter
- 5/17 STARTER commissioning tool
- 5/18 AS-Interface connecting cables
- 5/18 Connecting cables for digital inputs
- 5/18 Connecting cables pre-fabricated at one end and connector sets to connect to the line supply
- 5/19 Motor cables pre-fabricated at one end and connector sets to connect the inverter to the motor
- 5/19 Power bus distribution 400 V in IP65 degree of protection
- 5/19 Additional information

5/20 **Spare parts**

- 5/20 Spare Parts Kit
- 5/20 Replacement fan

SINAMICS G110D

Distributed inverters 0.75 kW to 7.5 kW (1.0 hp to 10 hp)

SINAMICS G110D distributed inverters

Overview

The new SINAMICS G110D distributed frequency inverter series is the solution for basic drive tasks especially in the field of conveyor systems. The inverter allows the speed of three-phase asynchronous motors to be continually controlled and fulfills the requirements of conveyor-related applications with open-loop frequency control. It can be optimally integrated into the system thanks to its compact and low-profile design in an IP65 degree of protection. This drive can be optimally integrated into the Siemens TIA world of automation via AS-Interface.

With its wide power range from 0.75 kW to 7.5 kW (1.0 hp to 10 hp), it is suitable for a wide range of distributed drive solutions.



Example: SINAMICS G110D, frame size FSA

Reasons for using distributed drive systems

- Modular drive solutions – therefore standardized mechatronic elements that can be individually tested
- A control cabinet is not required, resulting in a smaller space requirement and lower cooling requirements
- Long cables between the inverter and motor can be avoided (which means lower power losses, reduced noise emission and lower costs for shielded cables and additional filters)
- Distributed configurations offer considerable benefits for conveyor systems with their extensive coverage (e.g. in the automotive and logistics sectors)

Siemens family of distributed drives

Siemens offers an innovative portfolio of frequency inverters to optimally implement distributed drive solutions. The strengths of the individual members of the drive family permit simple adaptation to the widest range of application demands:

- Identical connection systems
- Identical mounting dimensions for SINAMICS G110D and SINAMICS G120D
- Standard commissioning and configuration tool

Products from the family of distributed drives:

- SINAMICS G110D frequency inverters
- SINAMICS G120D frequency inverters
- SIMATIC ET 200S FC drive converters
- SIMATIC ET 200pro FC drive converters
- SIRIUS M200D motor starters

Device design

SINAMICS G110D is a compact inverter in IP65 degree of protection where the Control Unit (CU) and Power Module (PM) function units are combined in one device.

The closed-loop control electronics controls and monitors the power electronics in several different control types that can be selected. The digital inputs and analog inputs on the device mean that sensors can be simply and directly connected at the drive. The input signals can either be directly linked within the closed-loop control or they can be transferred to the central control via AS-Interface for further processing within the context of the overall system.

The power electronics supplies the motor in the power range 0.75 kW to 7.5 kW (1.0 hp to 10 hp). It is controlled (open-loop) from the microprocessor-based control. State-of-the-art IGBT technology with pulse-width-modulation is used for highly reliable and flexible motor operation. It also features an extensive range of functions offering a high degree of protection for the inverter and motor. The unusually low profile mechanical design is optimized so that the device can be directly used in the plant or system. The compact inverter has the same drilling dimensions for all of the power ratings (standard "footprint"); further, the dimensions are identical to those of the SINAMICS G120D frequency inverter. This significantly simplifies the mechanical design and retrofitting of the system.

The latest technical documentation (catalogs, dimensional drawings, certificates, manuals and operating instructions), are available on the Internet under:

<http://www.siemens.com/sinamics-g110d/documentation>

and offline on the DVD CA 01 in the SD Configurator. In addition, the SD Configurator can be used on the Internet without requiring any installation. The SD Configurator can be found in the Siemens Mall under the following address:

<http://www.siemens.com/dt-configurator>

STARTER commissioning tool

The STARTER commissioning tool (from STARTER Version 4.1.3 and higher) supports the commissioning and maintenance of SINAMICS G110D inverters. The operator guidance combined with comprehensive, user-friendly functions for the relevant drive solution allow you to commission the device quickly and easily.

Applications

SINAMICS G110D is ideally suited for basic conveyor system applications in the industrial environment for which a distributed drive with communications capability is required. This is especially true for distribution logistics and for airports.

Further, SINAMICS G110D is suitable for many additional low-performance applications in many sectors, e.g. in the automobile sector, in the food and beverage industry (without tenside) and in the packaging industry.

SINAMICS G110D

Distributed inverters 0.75 kW to 7.5 kW (1.0 hp to 10 hp)

SINAMICS G110D distributed inverters

Selection and ordering data

Rated power ¹⁾		Rated output current ²⁾	Input current	Frame size	SINAMICS G110D with integrated class A line filter	SINAMICS G110D with integrated class A line filter and integrated maintenance switch
kW	hp	A	A		Order No.	Order No.
380 ... 500 V 3 AC ³⁾						
0.75	1	2.3	2.0	FSA	new 6SL3511-0PE17-5AM0	new 6SL3511-1PE17-5AM0
1.5	1.5 ⁴⁾	4.3	3.8	FSA	new 6SL3511-0PE21-5AM0	new 6SL3511-1PE21-5AM0
3	4	7.7	7.0	FSA	new 6SL3511-0PE23-0AM0	new 6SL3511-1PE23-0AM0
4	5	10.2	9.1	FSB	new 6SL3511-0PE24-0AM0	new 6SL3511-1PE24-0AM0
5.5	7.5	13.2	12.2	FSC	new 6SL3511-0PE25-5AM0	new 6SL3511-1PE25-5AM0
7.5	10	19.0	17.9	FSC	new 6SL3511-0PE27-5AM0	new 6SL3511-1PE27-5AM0

Benefits

- Wide power range from 0.75 kW to 7.5 kW (1.0 hp to 10 hp)
- Fast commissioning and maintenance as well as extended diagnostic functions and communications capability with AS interface according to specification 3.0
 - Reduced number of interfaces
 - Plantwide engineering
 - Easy to handle
- Mechanical design, installation and retrofit of systems are significantly simplified as a result of the compact and space-saving design with an extremely low profile and with the same drilling dimensions for all power ratings; further, the dimensions are identical with those of the SINAMICS G120D inverter.
- Simple commissioning and maintenance using the same, standardized connectors for the bus, power and I/O connections (ISO 23570) for the complete power range of SINAMICS G110D and SINAMICS G120D inverters.
- The same connectors are used as for the SIRIUS M200D motor starter
- Simple, standard implementation of completely distributed plant and system concepts by using products in a scalable fashion:
 - SIRIUS M200D (motor starter)
 - SINAMICS G110D (inverter for basic, conveyor-related applications)
 - SINAMICS G120D (inverter for sophisticated, conveyor-related applications)
- High degree of operator friendliness by using the Intelligent Operator Panel (IOP) to parameterize, diagnose, control (open-loop) and copy drive parameters in the IOP
- Easy to replace using a plug-in design and the use of a memory card provides the highest degree of service friendliness
- Simple connection, configuration, data management as well as control of the inverter in complex plants and systems as a result of the consequential integration in TIA (Totally Integrated Automation)
- Using the optional maintenance switch, the inverter can be simply disconnected from the line supply when service is required, without any additional components or without additional wiring costs when configuring the system
- Using the optional manual local control, commissioning is fast and can be limited to specific areas, the application can be manually pre-tested on site and the system can be cleared or emptied without requiring complex options.
- By being able to connect up to five sensors directly at the unit, practically all of the drive-relevant information can be directly managed; local pre-processing of the signals relieves the fieldbus to achieve fast and reproducible response times
- Integrated class A EMC filter (acc. to EN 55011)
- Integrated brake control, brake voltages that are supported, 400 V AC/180 V DC and 230 V AC/205 V DC
- Integrated motor protection using a thermal motor model and evaluation of PTC, Thermo-Click or KTY 84 temperature sensors
- Simple device replacement and fast copying of parameters to the memory card using the optional memory card holder and the optional MMC memory card
- Engineering and commissioning using standard engineering tools such as SIZER (from Version 3.2 and higher), STARTER (from Version 4.1.3 and higher) and Drive ES ensures fast configuration and simple commissioning – STARTER is integrated into STEP 7 with Drive ES Basic, with all of the benefits of central data management and unified communication
- Software parameters for simple adaptation to 50 Hz or 60 Hz motors (IEC or NEMA motors)
- Increased degree of ruggedness and longer service life as the electronic modules are coated
- Globally certified acc. to CE, UL, c-tick

¹⁾ Rated power based on the rated output current I_{rated} . The rated output current I_{rated} is based on the duty cycle for high overload (HO).

²⁾ The rated output current I_{rated} is based on the duty cycle for high overload (HO). These current values are valid for 400 V and are stamped on the rating plate.

³⁾ With the exception of UL operation, 500 V +10 % is possible.

⁴⁾ It is not possible to make any assignment to a particular standard.

SINAMICS G110D

Distributed inverters 0.75 kW to 7.5 kW (1.0 hp to 10 hp)

SINAMICS G110D distributed inverters

Design

The SINAMICS G110D distributed frequency inverters are compact frequency inverters for standard drives. Each SINAMICS G110D includes both the Control Unit as well as the Power Module in one unit.



Example: SINAMICS G110D with integrated maintenance switch and manual-local control with keyswitch

SINAMICS G110D features an integrated brake chopper and is suitable for distributed drives without energy recovery capability. If generator energy is produced then this is dissipated in the externally connected braking resistors. The communication is realized via the local inputs (digital and analog) or via the AS-Interface bus integrated as standard.



Example: SINAMICS G110D with integrated maintenance switch

The inverter is available in 2 versions: with or without maintenance switch. Using the optional maintenance switch (this cannot be retrofitted), when service is required, the inverter can be simply disconnected from the line supply without having to have any additional components or additional wiring costs when configuring.

Accessories

Braking resistors

Excess energy in the DC link is dissipated in the braking resistor. The braking resistors are designed for use with the SINAMICS G110D. This has an integrated brake chopper (electronic switch).

Intelligent Operator Panel IOP Handheld

User-friendly and powerful operator panel for commissioning and diagnostics as well as local operator control and monitoring of SINAMICS G110D.

Manual-local control with keyswitch

Master control can be toggled between the automatic mode (PLC) and manual-local mode using the manual-local control. This can also be used to switch off the inverter. Additional functions include switching over between the continuous and jog mode, starting the motor including direction of rotation and deactivating the quick stop in the manual mode.

MMC memory card

The parameter settings for an inverter can be stored on the MMC memory card. When service is required, e.g. after the inverter has been replaced and the data have been downloaded from the memory card the drive system is immediately ready for use again. The associated memory card holder is not included with the inverter and must be separately ordered.

Card holder for the MMC memory card

To use the MMC memory card, a card holder is required that is inserted under the blanking cover or under the manual-local control operator panel on the inverter.

RS232 interface cable for communication with a PC

For controlling and commissioning an inverter directly from a PC if the appropriate software (STARTER commissioning tool from Version 4.1.3 and higher) has been installed.

USB interface cable for communication with a PC

For controlling and commissioning an inverter directly from a PC if the appropriate software (STARTER commissioning tool from Version 4.1.3 and higher) has been installed.

Adapter to mount the SINAMICS G110D instead of a SIRIUS M200D motor starter

Connection Board Kit to mount a SINAMICS G110D inverter on the connection holes of the SIRIUS M200D motor starter (assuming that there is enough space).

Connecting cable

Connector sets to connect to the line supply and the outgoing motor feeder are available as accessories as well as pre-fabricated motor cables for connection to the motor.

Flexible plug-in cables to transfer data between AS-Interface participants as well as to supply the Control Unit and the Power Module with power.

Spare Parts Kit

A Spare Parts Kit is available which comprises small parts such as seals, caps and screws.

Replacement fan

A replacement fan is available, which comprises a pre-mounted unit with cover, fan and screws.

SINAMICS G110D

Distributed inverters 0.75 kW to 7.5 kW (1.0 hp to 10 hp)

SINAMICS G110D distributed inverters

Integration

The SINAMICS G110D distributed inverters have, as standard, the following interfaces:

- Motor connection via a HAN Q8 (connector) including control of the motor brake and temperature sensor
- Line supply connection via HAN Q4/2 (socket)
- Connection for a braking resistor in IP65 degree of protection through a three-pin connector
- AS-Interface connection via M12 (connector)
- Connection for four digital inputs via M12 (socket)
- Connection for an analog input via M12 (socket); this can also be used as digital input
- Connection for an AS-Interface addressing device via jack plug

The interfaces are identical to those of the SINAMICS G120D distributed inverter and those of the SIRIUS M200D motor starter.

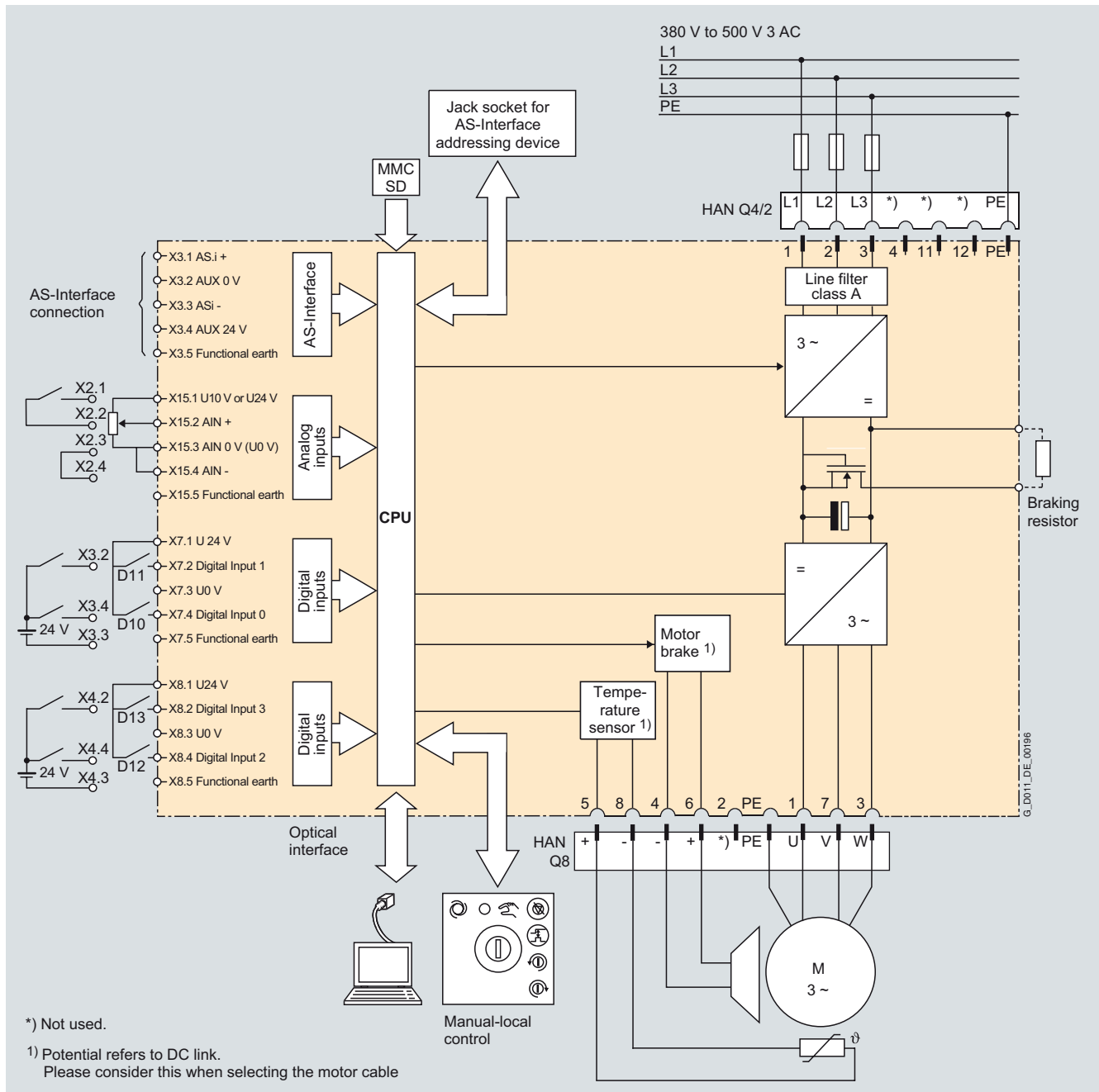

SINAMICS G110D connection diagram with integrated class A line filter

SINAMICS G110D

Distributed inverters 0.75 kW to 7.5 kW (1.0 hp to 10 hp)

SINAMICS G110D distributed inverters

Configuration

The following electronic configuring aids and engineering tools are available for the SINAMICS G110D distributed inverters:

Selection guide, SD Configurator within the CA 01

More than 100.000 products with approximately 5 million possible product versions from the area of drive technology are listed in the Interactive Catalog CA 01 – the Offline Mall from Siemens IA&DT. In order to make it easier to select the optimum motor and/or inverter from the wide range of Standard Drives, the SD Configurator was developed, which is integrated as “Selection guide” in this catalog on the DVD with the selection and configuration tools.

Online SD Configurator

In addition, the SD Configurator can now be used on the Internet without requiring any installation. The SD Configurator can be found in the Siemens Mall under the following address:

<http://www.siemens.com>

STARTER commissioning tool

The STARTER commissioning tool allows menu-prompted commissioning, optimization and diagnostics.

In addition to SINAMICS drives, STARTER is also suitable for MICROMASTER 4 units and the drive converters for the distributed I/O SIMATIC ET 200S FC and SIMATIC ET 200pro FC. For SINAMICS G110D from STARTER Version 4.1.3 and higher.

Drive ES engineering system

Drive ES is the engineering system that can be used to integrate the communication, configuration and data management functions of Siemens drive technology into the SIMATIC automation world easily, efficiently and cost-effectively. Therefore the STEP 7 Manager user interface forms the basis. Various software packages are available for SINAMICS: Drive ES Basic, Drive ES SIMATIC and Drive ES PCS 7.

Technical specifications

Unless explicitly specified otherwise, the following technical specifications are valid for all SINAMICS G110D distributed inverters.

General technical specifications	
Mechanical specifications	
Vibratory load according to EN 60068-2-6	
• Transport ¹⁾	5 ... 9 Hz: Constant deflection, 3.1 mm 9 ... 200 Hz: Constant acceleration = 9.81 m/s ² (1 × g)
• Operation	2 ... 9 Hz: Constant deflection, 7 mm 9 ... 200 Hz: Constant acceleration = 19.62 m/s ² (2 × g)
Shock according to EN 60068-2-27	
• Transport ¹⁾	147.15 m/s ² (15 × g)/11 ms 3 Shocks in each axis and direction
• Operation	147.15 m/s ² (15 × g)/11 ms 3 Shocks in each axis and direction
Degree of protection	IP65
Ambient conditions	
Protection class acc. to EN 61800-5-1	Class III (PELV)
Touch protection according to EN 61800-5-1	Class I (with protective conductor system)
Max. humidity	95 % at 40 °C
Ambient temperature	
• Storage ¹⁾ acc. to EN 60068-2-1	-40 ... +70 °C
• Transport ¹⁾ acc. to EN 60068-2-1	-40 ... +70 °C
• Operation acc. to EN 60068-2-2	-10 ... +40 °C without derating > 40 ... 55 °C see derating characteristics
Environmental class/harmful chemical substances	
• Operation acc. to EN 60721-3-3	Class 3C2
Degree of pollution acc. to EN 61800-5-1	2
Standards	
Compliance with standards	UL 508C (UL list number E121068), CE, c-tick
CE mark	According to Low-Voltage Directive 73/23/EEC and Machinery Directive 98/37/EC
EMC Directive ²⁾	
• Frame sizes FSA to FSC with integrated class A line filter	Category C2 ³⁾ acc. to EN 61800-3 (corresponds to class A acc. to EN 55011)

Note: The EMC product standard EN 61800-3 does not apply directly to a frequency inverter but to a PDS (Power Drive System), which comprises the complete circuitry, motor and cables in addition to the inverter. The frequency inverters on their own do not generally require identification according to the EMC Directive.

¹⁾ In transport packaging.

²⁾ For further general information, see also SINAMICS G110 section Technical specifications, Compliance with standards.

³⁾ With shielded motor cables up to 15 m.

SINAMICS G110D

Distributed inverters 0.75 kW to 7.5 kW (1.0 hp to 10 hp)

SINAMICS G110D distributed inverters

Technical specifications

Technical specifications, control electronics

Electrical specifications

Operating voltage	external 24 V DC necessary
Current consumption, max. ¹⁾ (from the non-switched 24 V supply, yellow AS-Interface cable)	320 mA
Current consumption, max. (from the switched 24 V supply, black AS-Interface cable)	
• Without supplementary fan	180 mA
• With supplementary fan	350 mA
Fixed frequencies	6, parameterizable
Interfaces	
Digital inputs	4
Analog inputs (0 ... 10 V)	1
Bus interface	AS-Interface
PTC/KTY interface	Connection via Power Module
• Motor temperature sensor	1 input, sensors that can be connected: PTC, KTY or Thermo-Click
Control of a mechanical motor brake	Connection via Power Modules
MMC memory card slot	Optional
RS232 interface	Connection with RS232 interface cable via the optical inverter interface
USB interface	Connection with USB interface cable via the optical inverter interface
Open-loop/closed-loop control technique and software	
V/f linear/square/parameterizable	✓
V/f with flux current control (FCC)	✓
Software functions	<ul style="list-style-type: none"> • Signal interconnection with BICO technology • Automatic restart after line supply failure or operational fault • Slip compensation • Free function blocks (FFB) for logic operations • Ramp smoothing • 3 selectable drive data sets • 3 selectable command data sets (CDS) (manual/auto) • Flying restart • JOG • Technology controller (PID) • Thermal motor protection • Thermal inverter protection • Setpoint input • Motor identification • Motor holding brake

¹⁾ Includes the current consumption of connected sensors.
Analog input as voltage input, 0 V to 10 V.

SINAMICS G110D

Distributed inverters 0.75 kW to 7.5 kW (1.0 hp to 10 hp)

SINAMICS G110D distributed inverters

Technical specifications

General technical specifications, power electronics	
System operating voltage	380 ... 500 V 3 AC ±10 %
Line supply requirements, line short circuit voltage u_K	no restriction
Input frequency	47 ... 63 Hz
Output frequency • Control type V/f	0 ... 650 Hz
Pulse frequency	4 kHz (Standard), higher pulse frequencies up to 16 kHz, see the derating data
Power factor	0.7 ... 0.85
Inverter efficiency η	95 %
Modulation depth	95 %
Overload capability • High overload (HO)	<ul style="list-style-type: none"> • Average maximum rated output current during a cycle time of 300 s • 1.5 × rated output current (i.e. 150 % overload) over 60 s at a cycle time of 300 s • 2 × rated output current (i.e. 200 % overload) over 3 s at a cycle time of 300 s
Electromagnetic compatibility	Integrated class A line filter according to EN 55011
Possible braking methods • Output current, max.	DC braking integrated brake control 180 V DC (corresponds to 400 V AC rectified) and 205 V DC (corresponds to 230 V AC rectified) Shutdown on the DC side permits "fast" braking. <ul style="list-style-type: none"> • 600 mA (with UL approval) • 1 A (without UL approval)
Permissible mounting position	Horizontal wall mounting and mounting in the horizontal position
Relative humidity	< 95 % RH, condensation not permissible
Cooling	<ul style="list-style-type: none"> • FSA: Convection • FSB and FSC: Air cooling as required using the integrated fan
Installation altitude	<ul style="list-style-type: none"> • Up to 1000 m above sea level without power reduction • > 1000 m see derating characteristics
Standard Short Circuit Current Rating (SCCR) ¹⁾	10 kA
Protection functions	<ul style="list-style-type: none"> • Undervoltage • Overvoltage • Overcontrol/overload • Ground fault • Short circuit • Stall protection • Motor blocking protection • Motor overtemperature • Inverter overtemperature • Parameter locking
Standards conformance	UL 508C (UL list number E121068), CE, c-tick
CE mark	According to Low-Voltage Directive 73/23/EEC and Machinery Directive 98/37/EC

¹⁾ Applies to industrial control cabinet installations to NEC Article 409/UL 508A. For further information, visit us on the Internet at: <http://support.automation.siemens.com/WW/view/en/23995621>

SINAMICS G110D

Distributed inverters 0.75 kW to 7.5 kW (1.0 hp to 10 hp)

SINAMICS G110D distributed inverters

Technical specifications

Line supply voltage 380 ... 500 V 3 AC		SINAMICS G110D					
		6SL3511- .PE17-5AM0	6SL3511- .PE21-5AM0	6SL3511- .PE23-0AM0	6SL3511- .PE24-0AM0	6SL3511- .PE25-5AM0	6SL3511- .PE27-5AM0
Rated output current I_{rated} ¹⁾	A	2.3	4.3	7.7	10.2	13.2	19
Output current I_{max}	A	4.6	8.6	15.4	20.4	26.4	38
Rated pulse frequency	kHz	4	4	4	4	4	4
Efficiency η	%	0.95	0.95	0.95	0.95	0.95	0.95
Rated power	kW (hp)	0.75 (1.0)	1.5 (1.5) ³⁾	3 (4.0)	4 (5.4)	5.5 (7.4)	7.5 (10)
Rated input current ²⁾	A	2.0	3.8	7.0	9.1	12.2	17.9
Line supply connection U1/L1, V1/L2, W1/L3, PE		HAN Q4/2 (connector)	HAN Q4/2 (connector)	HAN Q4/2 (connector)	HAN Q4/2 (connector)	HAN Q4/2 (connector)	HAN Q4/2 (connector)
• Conductor cross-section	mm ²	1.5 ... 6	1.5 ... 6	2.5 ... 6	2.5 ... 6	4 ... 6	4 ... 6
Motor connection U2, V2, W2, PE, motor brake, tem- perature sensor		HAN Q8 (socket)	HAN Q8 (socket)	HAN Q8 (socket)	HAN Q8 (socket)	HAN Q8 (socket)	HAN Q8 (socket)
• Conductor cross-section	mm ²	1 ... 4	1 ... 4	2.5 ... 4	2.5 ... 4	4	4
Motor cable length, max.	m	15	15	15	15	15	15
Degree of protection		IP65	IP65	IP65	IP65	IP65	IP65
Dimensions							
• Width	mm	450	450	450	450	450	450
• Height	mm	210	210	210	210	210	210
• Depth							
- Without maintenance switch	mm	125	125	125	165	240	240
- With maintenance switch	mm	145	145	145	165	240	240
Frame size		FSA	FSA	FSA	FSB	FSC	FSC
Weight, approx.							
• Without maintenance switch	kg	6.7	6.7	6.9	7.4	9.4	9.5
• with maintenance switch	kg	7.0	7.0	7.2	7.7	9.7	9.8

¹⁾ The rated output current I_{rated} is based on the duty cycle for high overload (HO).

²⁾ The input current depends on the motor load and line impedance. The input currents apply for load at rated power for a line impedance corresponding to $u_K = 1\%$.

³⁾ It is not possible to make any assignment to a particular standard.

SINAMICS G110D

Distributed inverters 0.75 kW to 7.5 kW (1.0 hp to 10 hp)

SINAMICS G110D distributed inverters

Characteristic curves

Derating data

Pulse frequency

Rated power at 400 V 3 AC		Rated output current in A for a pulse frequency of						
kW	hp	4 kHz	6 kHz	8 kHz	10 kHz	12 kHz	14 kHz	16 kHz
0.75	1.0	2.2	1.9	1.5	1.3	1.1	1.0	0.9
1.5	1.5 ¹⁾	4.1	3.5	2.9	2.5	2.1	1.8	1.6
3.0	4.0	7.7	6.5	5.4	4.6	3.9	3.5	3.1
4.0	5.0	10.2	8.7	7.1	6.1	5.1	4.6	4.1
5.5	7.5	13.2	11.2	9.2	7.9	6.6	5.9	5.3
7.5	10	19	16.2	13.3	11.4	9.5	8.6	7.6

Ambient temperature

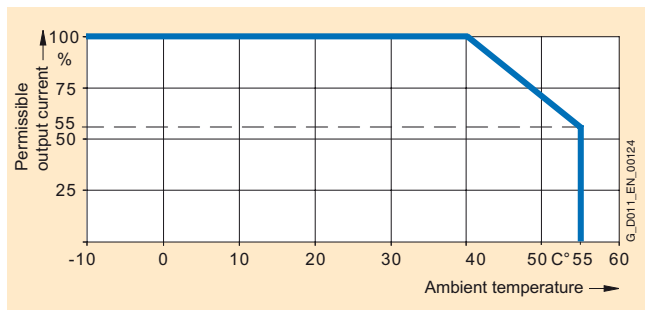

Installation altitude

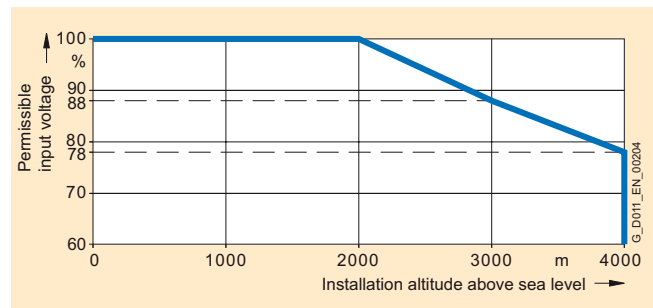
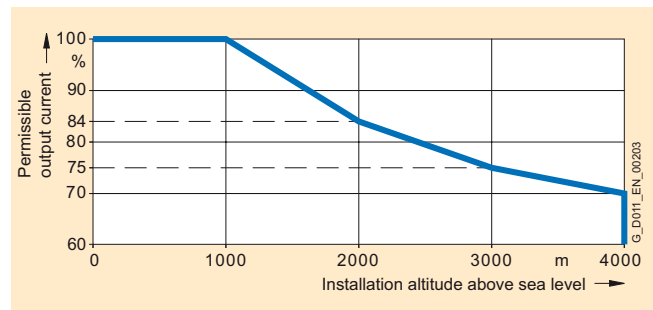

5

¹⁾ It is not possible to make any assignment to a particular standard.

SINAMICS G110D

Distributed inverters 0.75 kW to 7.5 kW (1.0 hp to 10 hp)

SINAMICS G110D distributed inverters

Dimensional drawings

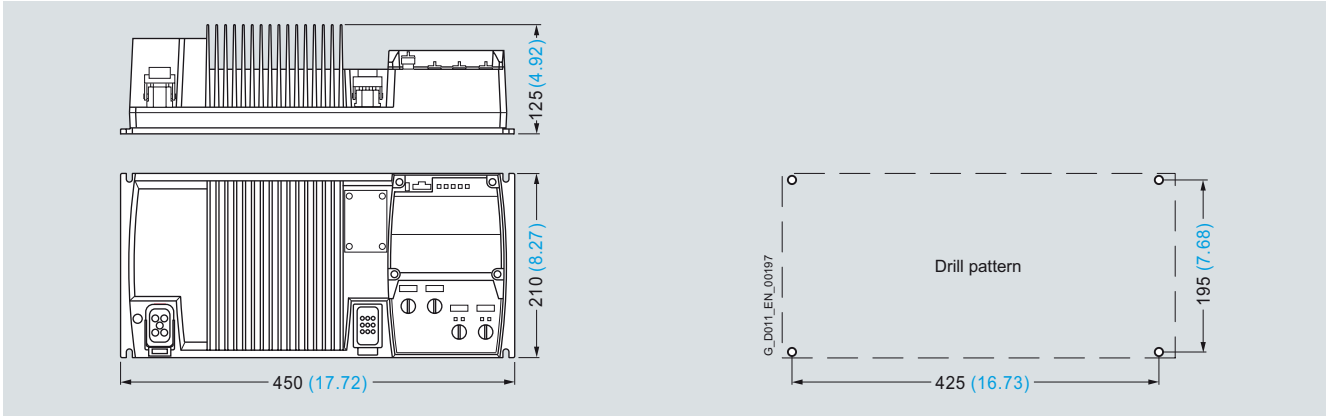

SINAMICS G110D, frame size FSA with integrated class A line filter

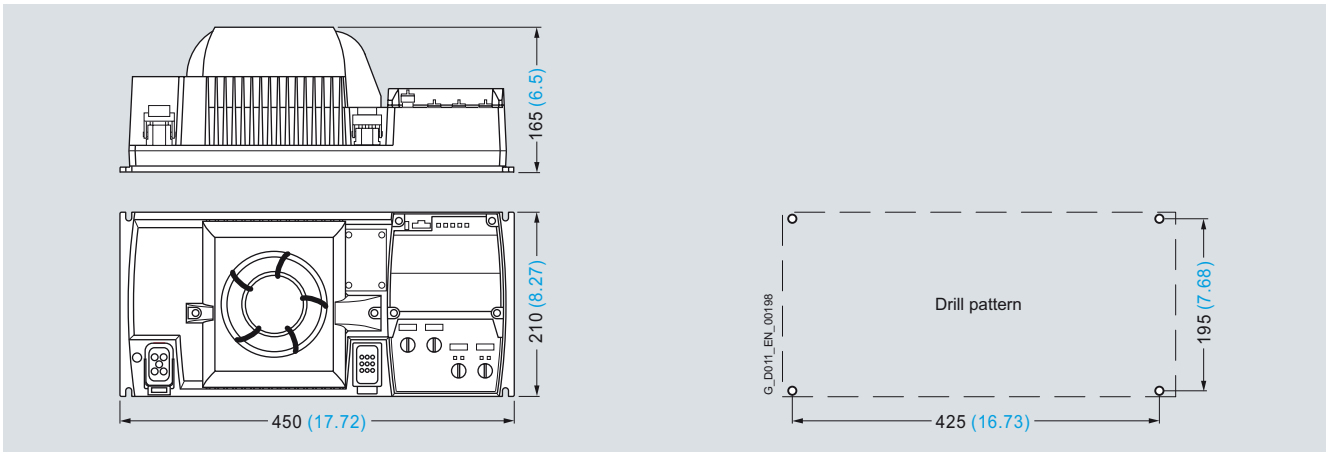

SINAMICS G110D, frame size FSB with integrated class A line filter

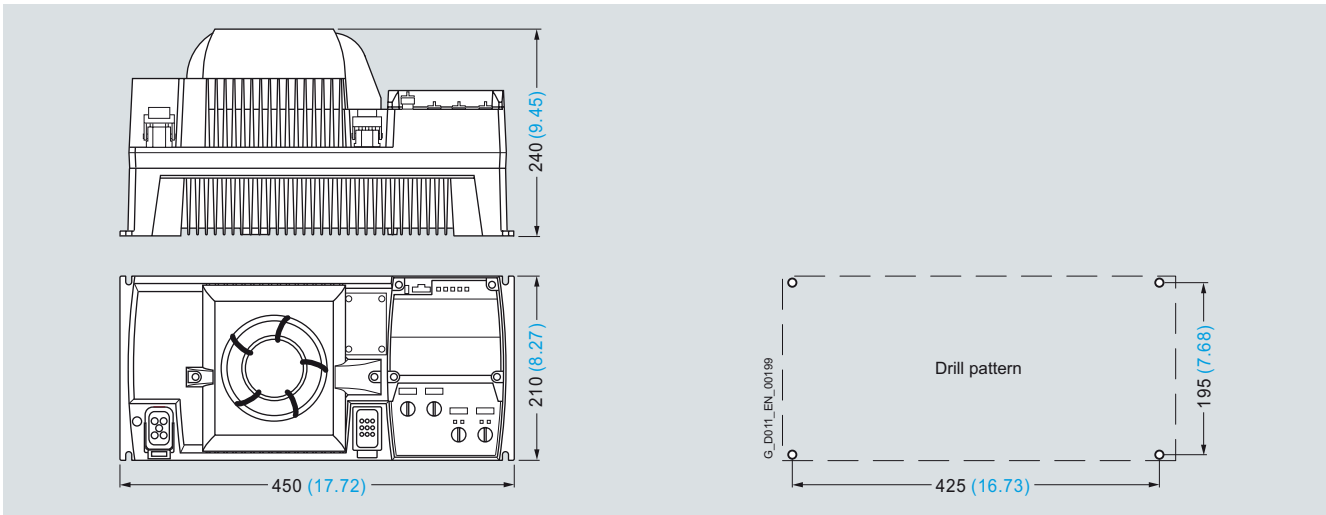

SINAMICS G110D, frame size FSC with integrated class A line filter

Mounted with 4 M5 studs, 4 M5 nuts, 4 M5 washers.

Ventilation clearance required (for wall mounting) at top and bottom: 150 mm (5.9 inches).

All dimensions in mm (values in brackets are in inches).

SINAMICS G110D

Distributed inverters 0.75 kW to 7.5 kW (1.0 hp to 10 hp)

SINAMICS G110D distributed inverters

Dimensional drawings

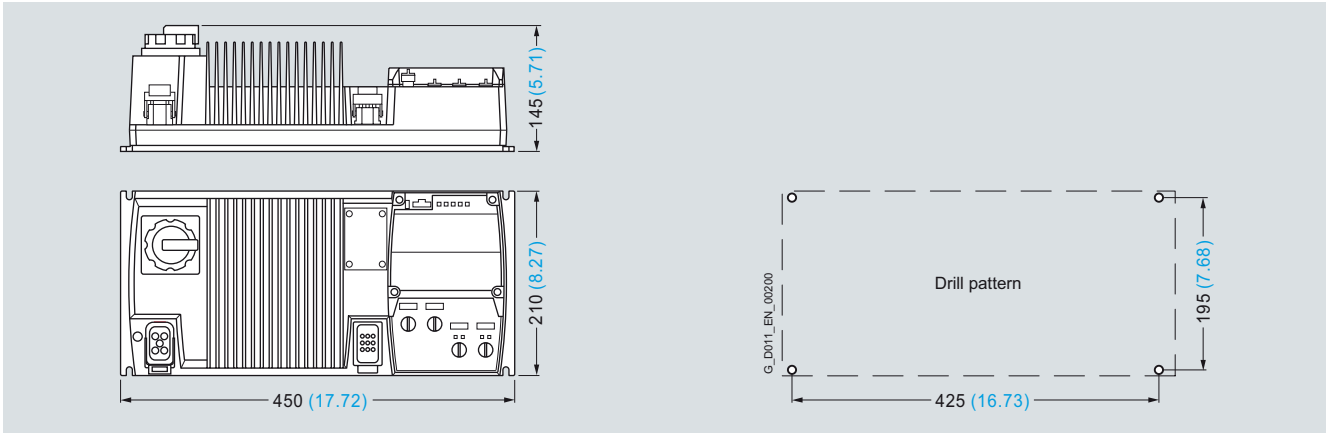

SINAMICS G110D, frame size FSA with integrated class A line filter and maintenance switch

5

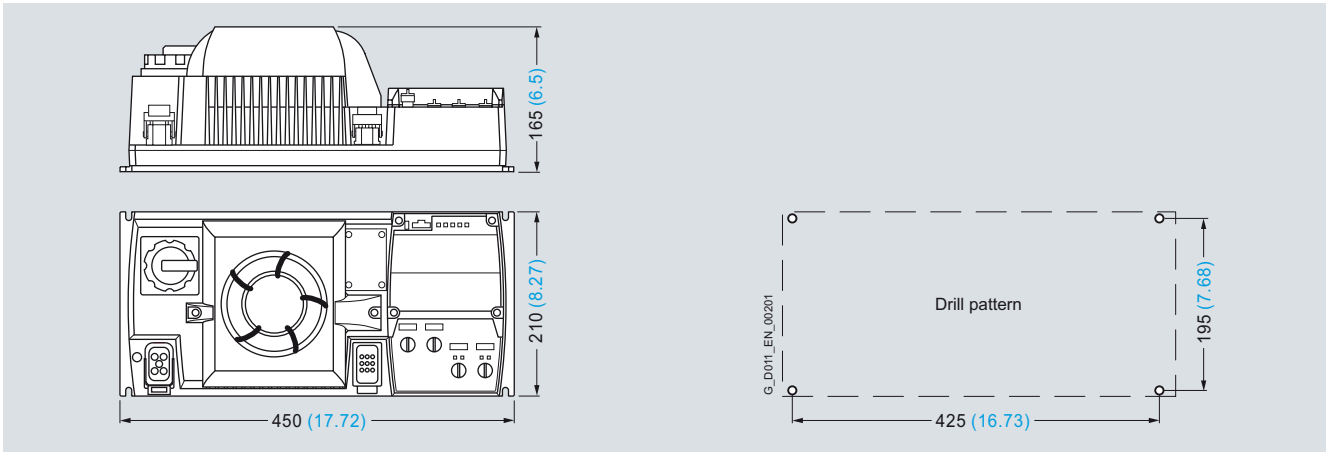

SINAMICS G110D, frame size FSB with integrated class A line filter and maintenance switch

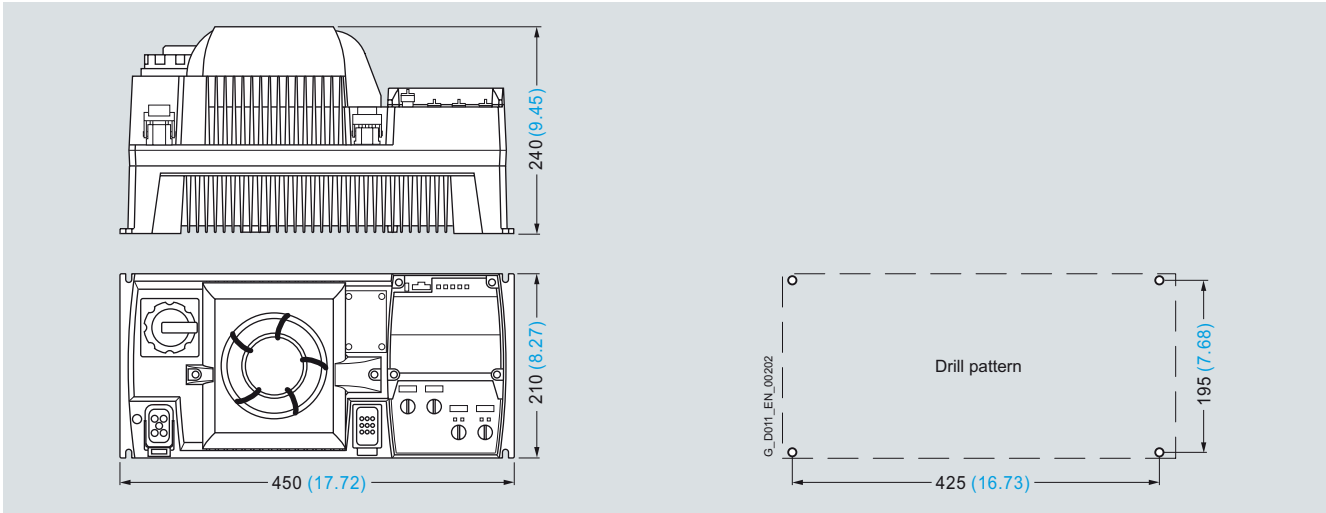

SINAMICS G110D, frame size FSC with integrated class A line filter and maintenance switch

Mounted with 4 M5 studs, 4 M5 nuts, 4 M5 washers.

Ventilation clearance required (for wall mounting) at top and bottom: 150 mm (5.9 inches).

All dimensions in mm (values in brackets are in inches).

SINAMICS G110D

Distributed inverters 0.75 kW to 7.5 kW (1.0 hp to 10 hp)

Recommended line components

Overview

The following table lists recommendations for additional line-side components, such as fuses and circuit breakers (line-side components dimensioned in accordance with IEC standards). The specified circuit breakers are UL-certified. 3NA3 fuses are recommended for European countries. The values in the table take into account the overload capability of the inverter.

Additional information about the listed fuses and circuit breakers can be found in Catalogs LV 1 and LV 1 T.

Selection and ordering data

For individual protection

Rated power		SINAMICS G110D		Protection	Fuse	Circuit breaker
kW	hp	Type 6SL3511-...	Frame size	A	Order No.	Order No.
380 ... 500 V 3 AC						
0.75	1	. PE17-5AM0	FSA	10	3NA3803	3RV1021-1FA10
1.5	1.5 ¹⁾	. PE21-5AM0	FSA	10	3NA3803	3RV1021-1JA10
3	4	. PE23-0AM0	FSA	26	3NA3805	3RV1021-4AA10
4	5	. PE24-0AM0	FSB	20	3NA3807	3RV1021-4BA10
5.5	7.5	. PE25-5AM0	FSC	20	3NA3807	3RV1031-4EA10
7.5	10	. PE27-5AM0	FSC	32	3NA3812	3RV1031-4FA10

Group protection

The group protection designates those configurations in which a circuit-breaker or a fuse provides protection for two or several devices and their feeder cables. The protective device is known as branch protection (BCP) device.

You will find additional information on the group protection and recommended types in the FAQ:

<http://support.automation.siemens.com/ww/view/en/31560253>

¹⁾ It is not possible to make any assignment to a particular standard.

SINAMICS G110D

Distributed inverters 0.75 kW to 7.5 kW (1.0 hp to 10 hp)

DC link components

Overview

Braking Resistors

Excess energy in the DC link is dissipated in the braking resistor. The braking resistors are intended for use with SINAMICS G110D, which have an integrated brake chopper, but cannot feed back generated energy to the line supply. For generator mode, e.g. braking a rotating mass with high moment of inertia, a braking resistor must be connected to convert the energy into heat.

The braking resistors can be mounted above and to the side of the SINAMICS G110D distributed inverter. The heat dissipated by the braking resistor must not diminish the inverter cooling. This is the reason that a minimum clearance of 150 mm must be maintained between the inverter and braking resistor.

Every braking resistor has thermal protection (UL-listed). The thermal protection prevents the braking resistor from being thermally overloaded.

All of the braking resistors are provided as standard with a cable; this is pre-fabricated and is 500 mm long.

Selection and ordering data

Rated power		Suitable for SINAMICS G110D		Braking resistor	
kW	hp	Type 6SL3511-...	Frame size	Order No.	
380 ... 500 V 3 AC					
0.75	1	. PE17-5AM0	FSA	new	6SL3501-0BE08-6AA0
1.5	1.5 ¹⁾	. PE21-5AM0	FSA		
3.0	10	. PE23-0AM0	FSA	new	6SL3501-0BE12-1AA0
4.0	4	. PE24-0AM0	FSB		
5.5	10	. PE25-5AM0	FSC	new	6SL3501-0BE14-1AA0
7.5	15	. PE27-5AM0	FSC		

Technical specifications

Line supply voltage 380 ... 500 V 3 AC		Braking resistor		
		6SL3501-0BE08-6AA0	6SL3501-0BE12-1AA0	6SL3501-0BE14-1AA0
Resistor	Ω	390	160	82
Rated power P_{DB}	kW	0.086	0.21	0.41
Peak power P_{max} (cycle time 12 s)	kW	1.725	4.2	8.2
Degree of protection		IP65	IP65	IP65
Dimensions				
• Width	mm	290	340	530
• Height	mm	150 ²⁾	150 ²⁾	150 ²⁾
• Depth	mm	140	140	140
Weight, approx.	kg	2.5	2.9	4.3
Suitable for SINAMICS G110D	Type	6SL3511-.PE17-5AM0 6SL3511-.PE21-5AM0	6SL3511-.PE23-0AM0 6SL3511-.PE24-0AM0	6SL3511-.PE25-5AM0 6SL3511-.PE27-5AM0
Frame size		FSA	FSA/FSB	FSC

¹⁾ It is not possible to make any assignment to a particular standard.

²⁾ For the specified height (150 mm) the required bending radius of the braking resistor connecting cable to the SINAMICS G110D has not been taken into account.

Accessories

Intelligent Operator Panel IOP Handheld



IOP Handheld for mobile use

The Intelligent Operator Panel IOP Handheld is a very user-friendly and powerful operator panel for commissioning and diagnostics as well as local operator control and monitoring of the SINAMICS G110D distributed inverter.

The IOP supports both entry-level personnel and drive experts. Thanks to the large plain text display, the menu prompting and the Application Wizards, it is easy to commission standard drives. A drive can be essentially commissioned without having to use a printed parameter list as the parameters are displayed in plain text, explanatory help texts are provided and the parameter filtering function.

Application Wizards interactively guide you when commissioning important applications such as conveyor technology, pumps, fans and compressors.

There are Quick Commissioning Wizards for general commissioning.

The drives are manually and simply controlled using directly assigned buttons and the navigation wheel. The IOP Handheld has a dedicated switchover key to switch over from the automatic to the manual mode.

The inverter can be diagnosed in a user-friendly fashion using the plain text display of faults and alarms. Help texts can be obtained by pressing the INFO button.

Up to two process values can either be graphically or numerically visualized on the status screen/status display.

Process values can also be displayed in technological units.

The IOP Handheld supports series commissioning of identical drives. For this purpose, a parameter list can be copied from an inverter into the IOP Handheld and when required, downloaded into other drive units of the same type.

The IOP Handheld includes the following language packages: English, French, German, Italian and Spanish.

In addition to the IOP, the IOP Handheld includes a housing with the rechargeable batteries, charging unit and RS232 interface cable. The charging unit is supplied with connector adapters for Europe, the US and UK. When the batteries are fully charged, the operating time is up to 8 hours.

To connect the IOP Handheld to SINAMICS G110D, the RS232 interface cable with optical interface is required in addition.

Updating the IOP Handheld

The IOP Handheld can be updated and expanded using the integrated USB interface.

Data to support future drive systems can be transferred from the PC to the IOP Handheld via drag & drop. Further, the USB interface allows user languages and Wizards that become available in the future to be subsequently downloaded and the firmware updated for the IOP Handheld.

The IOP is supplied with power via the USB interface during an update.

Selection and ordering data

Designation	Order No.
IOP Handheld For use with SINAMICS G120, SINAMICS G110D, SINAMICS G120D, SIMATIC ET 200S FC or SIMATIC ET 200pro FC Included in the scope of delivery: <ul style="list-style-type: none"> • IOP • Handheld housing • Rechargeable batteries (4 × AA) • Charging unit (international) • RS232 connecting cable (3 m long, can only be used for SINAMICS G120 and SIMATIC ET 200S FC) • USB cable (1 m long) 	new 6SL3255-0AA00-4HA0
RS232 interface cable With optical interface to connect the SINAMICS G110D, SINAMICS G120D or SIMATIC ET 200pro FC inverters to the IOP Handheld (2.5 m long)	3RK1922-2BP00

SINAMICS G110D

Distributed inverters 0.75 kW to 7.5 kW (1.0 hp to 10 hp)

Supplementary system components

Accessories

Manual-local control with keyswitch



Example: SINAMICS G110D and manual-local control with integrated keyswitch

The manual-local control is a simple method to locally control and commission the SINAMICS G110D distributed inverter.

To switch over from the automatic to the manual mode or to switch-off the inverter, there is a keyswitch that can be withdrawn in each of the three operating modes (Auto/Off/Local).

- The inverter is controlled via the PLC in the automatic mode
- In the OFF state, the device is shut down (however, the line supply voltage is still connected)
- The drive is locally and directly controlled in the "Local" setting. The device is simply controlled using directly assigned buttons. The following functions can be selected:
 - Switching over between continuous operation / jog mode
 - On/Counter-clockwise
 - On/Clockwise
 - Deactivate Quick Stop

The manual-local control is mounted on the inverter instead of the standard blanking cover. This means that it can be retrofitted at a later date.

Selection and ordering data

Designation	Order No.
Manual-local control with keyswitch	new 6SL3555-0PL00-2AA0

MMC memory card



The parameter settings for an inverter can be stored on the MMC memory card. When service is required, e.g. after the inverter has been replaced and the data have been downloaded from the memory card the drive system is immediately ready for use again. The card holder is not included with the inverter and must be separately ordered.

Selection and ordering data

	Order No.
MMC memory card	6SL3254-0AM00-0AA0

Accessories

Card holder for MMC/SD memory card



To use the MMC memory card, a card holder is required. This can be subsequently inserted under the blanking cover or under the optional manual-local control on the inverter – where it can also remain. In addition, a Secure Digital card (SD) can also be used.



SINAMICS G110D with integrated card holder (in the open state)

Selection and ordering data

	Order No.
Card holder for MMC/SD memory card	new 6SL3555-0PM00-0AA0

RS232 interface cable for communication with a PC

For controlling and commissioning an inverter directly from a PC via a point-to-point connection if the appropriate software (STARTER commissioning tool¹⁾, from Version 4.1.3 and higher) has been installed.

Selection and ordering data

	Order No.
RS232 interface cable for communication with a PC	3RK1922-2BP00

USB interface cable for communication with a PC

For controlling and commissioning an inverter directly from a PC via a point-to-point connection if the appropriate software (STARTER commissioning tool¹⁾, from Version 4.1.3 and higher) has been installed.

Selection and ordering data

	Order No.
USB interface cable for communication with a PC (2.5 m long)	new 6SL3555-0PA00-2AA0

Adapter to mount SINAMICS G110D instead of SIRIUS M200D motor starter

For adaptation, there are connection boards that allow SINAMICS G110D to be mounted onto existing connection holes of the SIRIUS M200D motor starter (assuming that there is sufficient space). This means that a system can be correspondingly adapted to different requirements at a later stage.

Selection and ordering data

	Order No.
Adapter to mount SINAMICS G110D instead of SIRIUS M200D motor starter	new 6SL3263-1GA20-0GA0

STARTER commissioning tool

The STARTER commissioning tool (STARTER Version from 4.1.3 and higher) supports the commissioning and maintenance of SINAMICS G110D inverters. The operator guidance combined with comprehensive, user-friendly functions for the relevant drive solution allow you to commission the device quickly and easily.

Selection and ordering data

	Order No.
STARTER commissioning tool¹⁾ on DVD	6SL3072-0AA00-0AG0

¹⁾ The STARTER commissioning tool is also available on the Internet under <http://support.automation.siemens.com/WW/view/en/10804985/133100>

SINAMICS G110D

Distributed inverters 0.75 kW to 7.5 kW (1.0 hp to 10 hp)

Supplementary system components

Accessories

AS-Interface connecting cables

Selection and ordering data

	Order No.
AS-Interface M12 branch To connect the AS-Interface and V_{Aux} cable to an M12 socket Length:	
• 1.0 m	new 3RK1901-1NR21
• 2.0 m	new 3RK1901-1NR22

Connecting cables for digital inputs

Selection and ordering data

	Order No.
M12 plug-in cables With PUR sheath, to connect digital sensors and actuators, pre-fabricated at one end, angled, plug connector, 5-pole, $5 \times 0.34 \text{ mm}^2$ length:	
• 1.5 m	new 3RX8000-1CE52-1AB5
• 5 m	new 3RX8000-1CE52-1AF0
• 10 m	new 3RX8000-1CE52-1AL0

Connecting cables pre-fabricated at one end and connector sets to connect to the line supply

Selection and ordering data

	Order No.
Connecting cable pre-fabricated at one end Power supply cable, open at one end, for HAN Q4/2, angled, $4 \times 4 \text{ mm}^2$	
• 1.5 m long	3RK1911-0DB13
• 5 m long	3RK1911-0DB33
Connector set for the power supply HAN Q4/2	
• 2.5 mm^2	3RK1911-2BE50
• 4 mm^2	3RK1911-2BE10
• 6 mm^2	3RK1911-2BE30

Accessories

Motor cables pre-fabricated at one end and connector sets to connect the inverter to the motor

Selection and ordering data

Motor cables pre-fabricated at one end		Order No.			
For motors with brake and temperature sensor with HAN Q8 connector, shielded		(HTG: supplied from the Harting Company) (ZKT: supplied from the KnorrTec Company)			
Cross-section	1 mm ²	1.5 mm ²	2.5 mm ²	4 mm ²	
• 1.5 m long	new ZKT: 70018601000150	HTG: 61 88 201 0288	new HTG: 61 88 201 0291	new ZKT: 70017001000150	new ZKT: 70017001000150
• 3 m long	new ZKT: 70018601000300	HTG: 61 88 201 0289	new HTG: 61 88 201 0292	new ZKT: 70009601000300	new ZKT: 70017001000300
• 5 m long	new ZKT: 70018601000500	HTG: 61 88 201 0290	new HTG: 61 88 201 0293	new ZKT: 70009601000500	new ZKT: 70017001000500
• 10 m long	new ZKT: 70018601001000	HTG: 61 88 201 0299	new HTG: 61 88 201 0301	new ZKT: 70009601001000	new ZKT: 70017001001000
Connector set for motor cables		Order No.			
Shielded, HAN Q8					
• up to 1.5 mm ²	–	6ES7194-1AB01-0XA0	–	–	–
Connector set for motor cables		Order No.			
Shielded, HAN Q8		(HTG: supplied from the Harting Company) (ZKT: supplied from the KnorrTec Company)			
• up to 2.5 mm ²	–	–	new HTG: 61 83 401 0132	–	–
			new ZKT: 10032011		
• up to 4 mm ²	–	–	–	new HTG: 61 83 401 0133	new ZKT: 10032021

Power bus distribution 400 V in IP65 degree of protection

	Ordering (see Solution Partner)
Power T clamp connector for 2.5 ... 6 mm² With attached 7-pole connector, socket insert, grommet housing, UL Seals for various cable cross-sections must be separately ordered	Ordered and supplied from the Harting Company
T clamp connector Completely pre-fabricated	Ordered and supplied from the KnorrTec Company
T distributor box, IDC connection, power cable Uncut power cable, 2.5 ... 6 mm ² , 2 outgoing feeders: Push-in connection: 1.5 ... 6 mm ² Seals for various cable cross-sections must be separately ordered	Ordered and supplied from the Weidmüller Company
T distributor box Completely pre-fabricated	Ordered and supplied from the KnorrTec Company

Additional information

For further information about the connecting cables and plug-in connectors mentioned above, please refer to Catalog IK PI.



Further selected accessories are available from Siemens Solution Partners. Select "Distributed Field Installation System" as technology in the "SolutionPartner Finder".
<http://www.siemens.com/automation/partnerfinder>

SINAMICS G110D

Distributed inverters 0.75 kW to 7.5 kW (1.0 hp to 10 hp)

Spare parts Spare Parts Kit

Spare parts Replacement fan

Overview

A Spare Parts Kit can be ordered which comprises small parts such as replacement seals, caps and screws.

Selection and ordering data

	Order No.
Spare Parts Kit for SINAMICS G110D <small>new</small>	6SL3500-0TK01-0AA0
Comprising replacement seals, caps and screws	

Overview

The fans are designed for an extra long service life. Replacement fans can be ordered for special applications.

Selection and ordering data

Rated power		SINAMICS G110D		Replacement fan	
kW	hp	Type	Frame size	Order No.	
380 ... 500 V 3 AC					
4	5	. PE24-0AM0	FSB	<small>new</small>	6SL3500-0TF01-0AA0
5.5	7.5	. PE25-5AM0	FSC	(pre-mounted unit with cover, fan and screws)	
7.5	10	. PE27-5AM0			